

# Environmental Product Declaration

In accordance with ISO 14025:2006 and  
EN 15804:2012+A2:2019/AC:2021 for:



# DuraGal® Clear



**AustubeMills**  
SHAPING POSSIBILITIES

Programme:	The International EPD System   <a href="http://www.environdec.com">www.environdec.com</a>
Programme operator:	EPD International AB
Licensee:	EPD Australasia   <a href="https://epd-australasia.com/">https://epd-australasia.com/</a>
Type of EPD:	EPD of multiple products, based on the average results of the product group.
Products covered in the EPD:	The Austube Mills DuraGal Clear product range
EPD registration number:	EPD-IES-0031054:001
Version date:	2026-05-15
Validity date:	2031-05-15

An EPD may be updated or republished if conditions change. To find the latest version of the EPD and to confirm its validity, see [www.environdec.com](http://www.environdec.com).



# Contents

---

Information about EPD owner .....	3
Product Information .....	5
Content Declaration .....	7
LCA Information .....	8
Environmental performance .....	22
General information .....	26
Version history .....	27
Abbreviations .....	28
References .....	29

# Information about EPD owner

Austube Mills (ATM) is a leading Australian manufacturer of structural steel tube and pipe products with a 90 year pedigree, manufacturing in Australia and overseas. From our Australian operations in Acacia Ridge, QLD, Newcastle, NSW, and Dalian, China, we supply high-quality tubular products to infrastructure, non-residential and residential construction, manufacturing, agriculture, and renewable energy projects across Australia and New Zealand. We combine locally made feedstock with advanced forming, welding and finishing processes to deliver durable, specification-compliant products and dependable service, second to none in the market.

This Environmental Product Declaration (EPD) suite covers six Austube Mills product offerings: DuraGal®, DuraGal® Clear, DuraPrimed®, FirePlus®, Austube Mills LSS (Large Structural Steel) range (mill black, oiled), and NOPC (no oil/paint coating). These products are engineered for longevity, fabrication efficiency and consistent dimensional quality, supporting designers and contractors to meet structural performance, durability and compliance requirements across a wide range of applications.

ATM's approach to sustainability centres on responsible sourcing, resource efficiency and circularity. Our operations prioritise yield optimisation, process energy management, water stewardship, off-cut and scrap recovery,

and end-of-life recyclability of steel. We work closely with customers, suppliers and industry bodies to improve environmental performance and provide transparent, verified information to support lower-carbon design choices as the key future direction of the business.

Product and management-system-related certifications (site scope as applicable):

- ISO 9001 Quality Management
- ISO 14001 Environmental Management
- ISO 45001 Occupational Health & Safety Management
- Product conformity to relevant Australian/New Zealand Standards for structural steel hollow sections and coatings (e.g., AS/NZS 1163, related fabrication/coating standards as applicable)
- Independent third-party testing and routine mill test certificates to support compliance, traceability and customer QA requirements

For more than 90 years, Austube Mills has supported Australian industry with manufactured tubular solutions, technical support and supply reliability. Publishing these EPDs is part of our commitment to independent verification and clear communication of product environmental performance.

INFORMATION ABOUT EPD OWNER	
<p><b>Declaration owner:</b></p>  <p><b>AustubeMills</b> SHAPING POSSIBILITIES</p>	<p><b>Austube Mills Pty Ltd</b></p> <p>Web: <a href="http://www.austubemills.com">www.austubemills.com</a></p> <p>Email: <a href="mailto:Info@austubemills.com">Info@austubemills.com</a></p> <p>Post: Industrial Drive, Mayfield NSW 2304</p>
LIFE CYCLE ASSESSMENT (LCA)	
<p><b>LCA Accountability:</b></p>  <p><b>thinkstep</b> anz</p>	<p><b>thinkstep Pty Ltd</b></p> <p>Barbara Nebel Gustavo Moraga Edwin Chu</p> <p>Web: <a href="http://www.thinkstep-anz.com">www.thinkstep-anz.com</a></p> <p>Email: <a href="mailto:anz@thinkstep-anz.com">anz@thinkstep-anz.com</a></p> <p>Post: 25 Jubilee Street, South Perth, Western Australia 6151, Australia</p>

[www.austubemills.com](http://www.austubemills.com)

## AUSTUBE MILLS MANUFACTURING FOOTPRINT

Austube Mills is a long-established manufacturer of structural tubular steel products, with a manufacturing footprint spanning Acacia Ridge in Queensland, Newcastle in New South Wales, and Dalian in China. Originating from the legacy of Stewarts & Lloyds, the Australian business has been operating for over 90 years, underpinning local industry with reliable, high-quality tubular steel products.

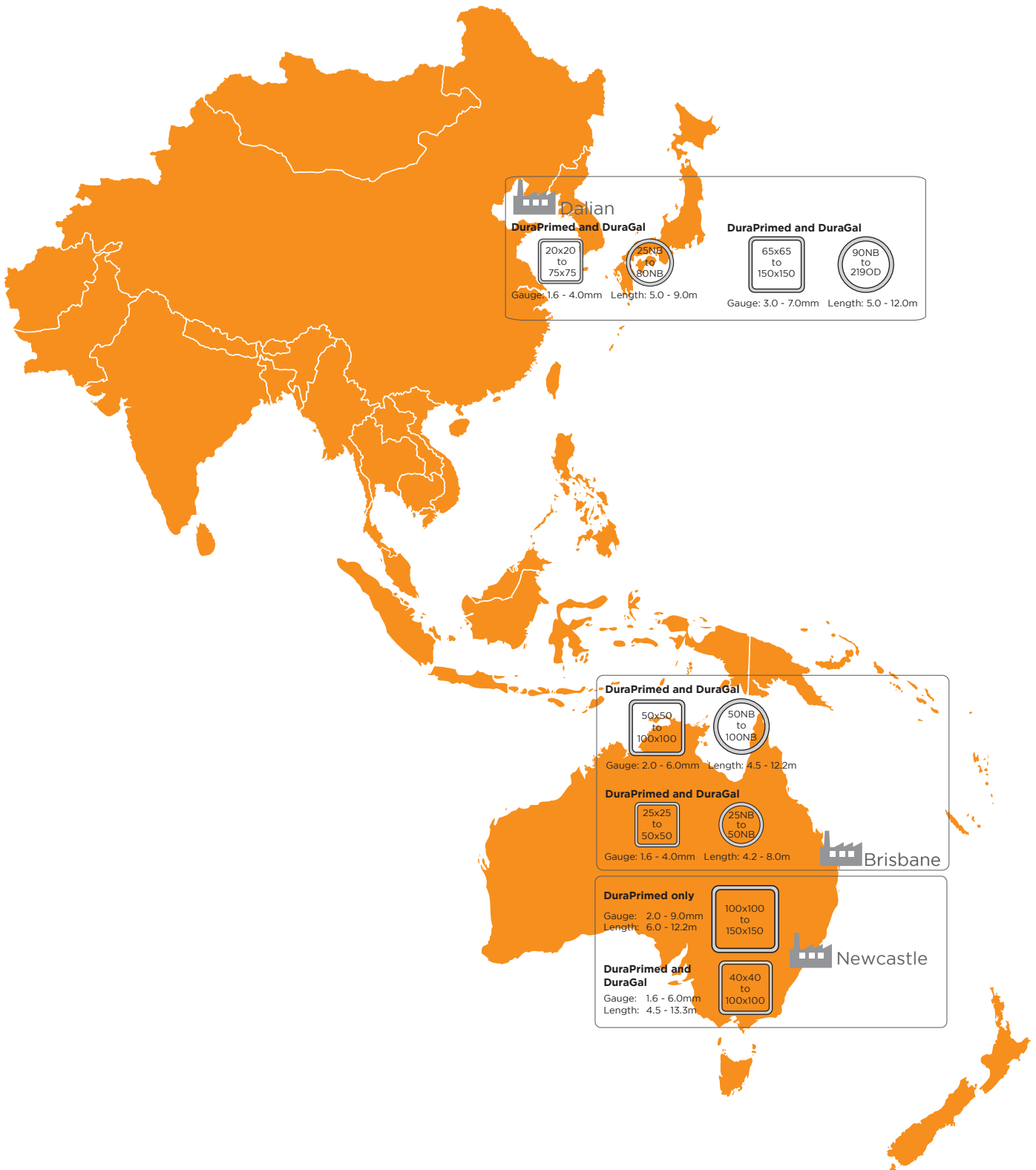

# Product Information

## PRODUCTS COVERED BY EPD

### DuraGal® Clear:

The product is formed from pre-galvanised steel strip. After forming/welding and standard finishing, a uniquely engineered water-based coating to promote top coat adhesion is applied on ATM production lines (mills).

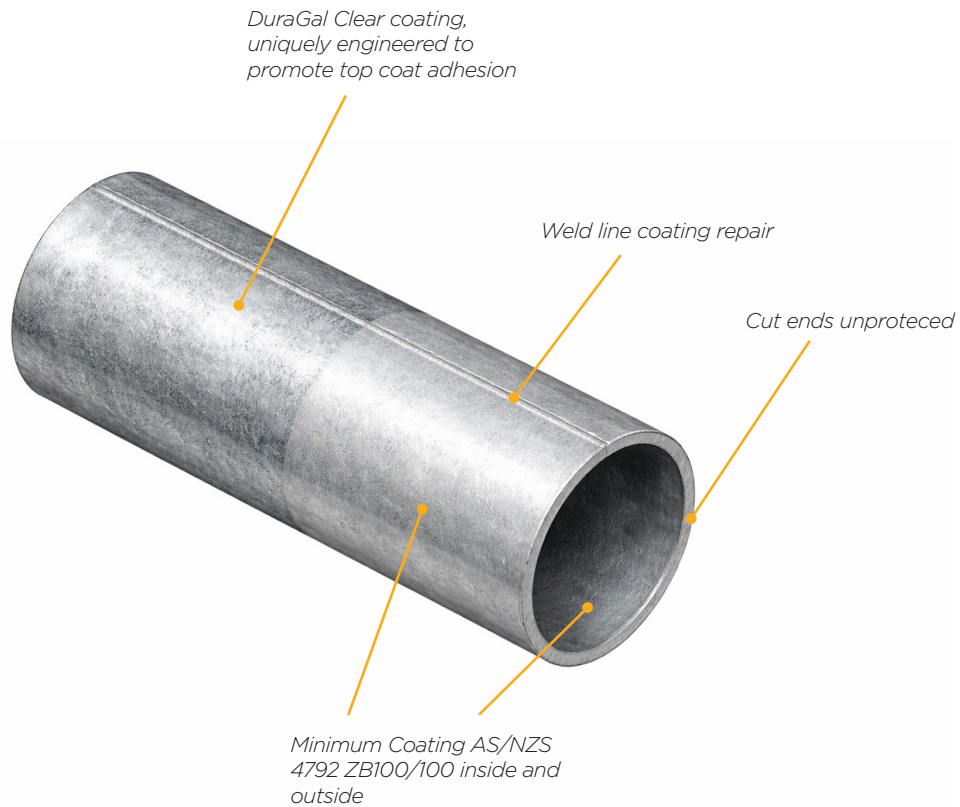



DuraGal® Clear products are produced at all three of the Austube Mills Manufacturing sites.

**Technical purpose & intended use**

- Structural hollow sections for building, infrastructure, general engineering and fabrication.
- Factory-applied, water-based adhesion promoter.
- The coating can be welded-through and cut-through, and provides a ready-to-overcoat surface to reduce site preparation time.
- Not a final protective coating; for long-term durability, and not designed as a coating to protect against water damage.

**Standards the product conforms to**

Aspect	Standard / Notes
Structural hollow sections (CHS/RHS/SHS)	AS/NZS 1163 & AS/NZS 1450 - Grades C250, C350, C450 (cold-formed), including mechanical properties, chemistry and tolerances
NDT & verification	Testing performed in accordance with AS/NZS 1163 requirements (e.g., eddy-current NDT, scheduled destructive testing)

**Table 1: Industry classification**

Product	Classification	Code	Category
Product name/type	UN CPC Ver.2	41283; 41284	Other tubes and pipes, of circular cross-section, seamless; Tubes and pipes, of non-circular cross-section and hollow profiles, seamless, of steel
	ANZSIC 2006	2122	Steel Pipe and Tube Manufacturing

# Content Declaration

The content declaration for this EPD of multiple products is based on the average results of the product group.

**Table 2: Composition of DuraGal® Clear (per 1 t)**

Product components	Mass, kg	Post-consumer recycled material, mass-% of product	Biogenic material, mass-% of product	Biogenic material, kg C/product or declared unit
Galvanised steel coil	9.98E+02	0	0	0
Silane (resin and solvent)	1.45E+00	0	0	0
Other paint coatings and ink	1.92E-02	0	0	0
Weld repair coils (zinc/aluminium)	3.05E-02	0	0	0
Welding wire (steel)	1.17E-02	0	0	0
<b>Total</b>	<b>1.00E+03</b>	<b>0</b>	<b>0</b>	<b>0</b>

**Table 3: Composition of packaging for DuraGal® Clear (per 1 t)**

Packaging materials	Mass, kg	Mass- % (versus the product)	Biogenic material, kg C/product or declared unit
Steel strap	6.80E-02	0.0068%	0
Plastic strap	1.37E-03	0.00014%	0
Plastic label	5.74E-03	0.00057%	0
Magnetic label	2.33E-05	0.000002%	0
<b>Total</b>	<b>7.51E-02</b>	<b>0.0075%</b>	<b>0</b>

## Dangerous substances from the candidate list of SVHC for Authorisation

No products declared within this EPD contain substances exceeding the limits for registration according to the European Chemicals Agency's "Candidate List of Substances of Very High Concern for authorisation".

# LCA Information

Note: In compliance with the PCR the thousand separator and decimal mark in the EPD follows the SI style (English version): 1 234.56. This is different to the commonly used number format in Australasia: 1,234.56.

## DECLARED UNIT

The declared unit for the EPD is 1 tonne of product (1 000 kg).

## SYSTEM BOUNDARIES

As shown in the table below, this EPD is of the type a) Cradle to gate with modules C1-C4 and module D (A1-A3 + C + D). Other life cycle stages (Modules A4-A5, B1-B7) are dependent on particular scenarios and best modelled at the building level.

**Table 4: Modules included in the scope of the EPD**

	Product stage			Construction process stage		Use stage							End-of-life stage				Resource recovery stage
	Raw material supply	Transport of raw materials	Manufacturing	Transport to customer	Construction / Installation	Use	Maintenance	Repair	Replacement	Refurbishment	Operational energy use	Operational water use	Deconstruction / demolition	Transport to waste processing	Waste processing	Disposal	Reuse/ recovery/ recycling potential
Module	A1	A2	A3	A4	A5	B1	B2	B3	B4	B5	B6	B7	C1	C2	C3	C4	D
Modules declared	X	X	X	ND	ND	ND	ND	ND	ND	ND	ND	ND	X	X	X	X	X
Geography	AU/ GLO	AU/ GLO	AU/ CN										AU	AU	AU	AU	GLO

X = included in the EPD; ND = Module not declared (such a declaration shall not be regarded as an indicator result of zero)

## PRODUCT STAGE (MODULE A1-A3)

### Module A1

Austube's steel tubes are composed of zinc-coated structural steel or hot-rolled steel with a range of coatings applied. The steel is made from iron ore and steel scrap, while coatings consist of chemicals and minerals. Module A1 includes the extraction and processing of all raw materials used in Austube manufacturing.

Module A1 includes the upstream production of electricity and energy carriers (natural gas, oil, coal, and other fuels) required for the extraction and processing of raw materials, such as iron ore, pig iron, and chemicals used in coating. This includes energy needed for raw material supply and energy for manufacturing in the core process.

### Module A2

Module A2 includes the inbound transport of the raw materials (i.e. steel, coatings, etc.) to the manufacturing sites by truck. Additionally, Australian steel is transported by train to the Acacia Ridge site. Some coatings are sourced from overseas suppliers and are shipped to local ports before being transported by truck to the manufacturing sites.

## Module A3

Quality and compliance testing: ATM employs eddy current NDT in accordance with AS/NZS 1163, supported by specialised operator inspections and destructive verification testing at defined frequencies.

### ERW Process - Step 1

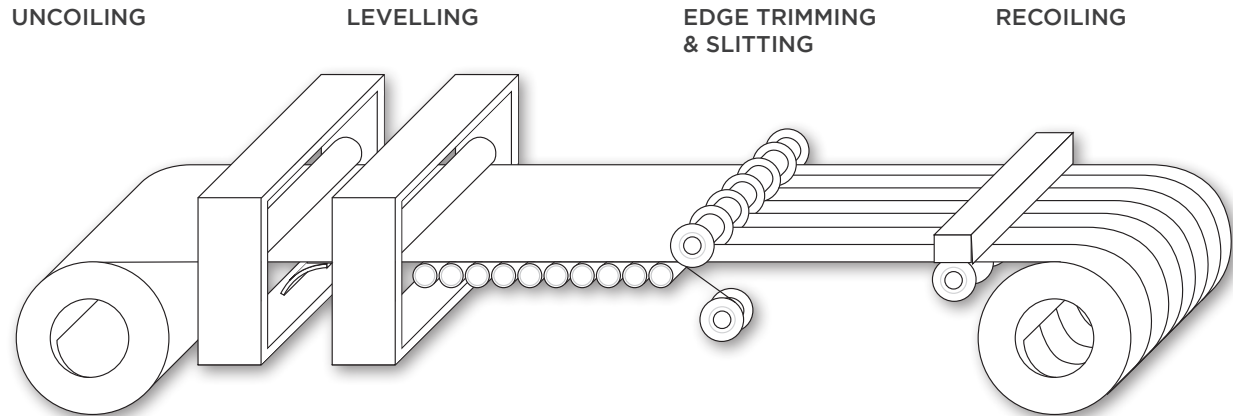

#### Raw Material Handling

1.0 – 1.5 metre wide rolls of steel coil are processed to make welded steel tube. Each coil weighs anywhere from 18 to 27 tonnes. After careful inspection and measurement to ensure the material is correct, the coils are placed in a storage area. The coil ends are prepared for the start of the milling process by uncoiling and levelling. The edges are trimmed and the flat steel is then slit into the required widths to suit different products.

They are then recoiled and the trimmed edges plus offcuts are collected for recycling as scrap metal.

#### Pre-mill Preparation

A fully computerised production log schedule selects which coils will be processed through the mill. At this stage, information on the coils and mults (i.e. slit sub-multiples of the coil) is entered into a computer system so that the end product can be traced for quality control purposes.

### ERW Process - Step 2

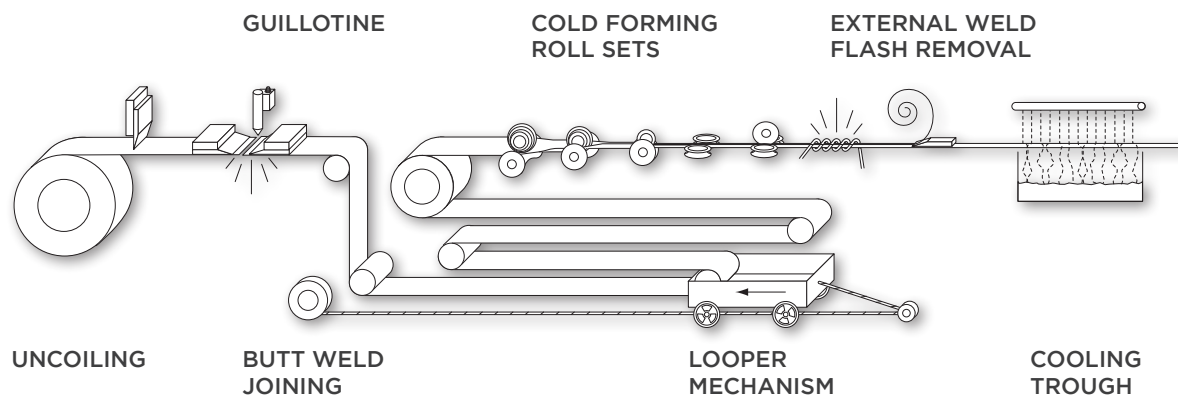

#### Mill Entry

Selected slit coils are taken from storage to meet production demands. Lengths are joined by a combination guillotine/welding process. This does not halt production because a looper (or accumulator) allows a loop of steel strip to feed the mill while the joining operation takes place.

#### Cold Forming and Welding

A long series of forming rolls forms the flat steel into tube. The steel is not heated and this gradual cold forming process enhances the strength of the steel and allows for very tight dimensional tolerances.

When the edges of the tube are pushed together by squeeze rolls, they are welded using Electric Resistance Welding (ERW).

The external weld flash is removed by special scarfing tools and the pipe is cooled uniformly in a cooling trough.

**ERW Process – Step 3**

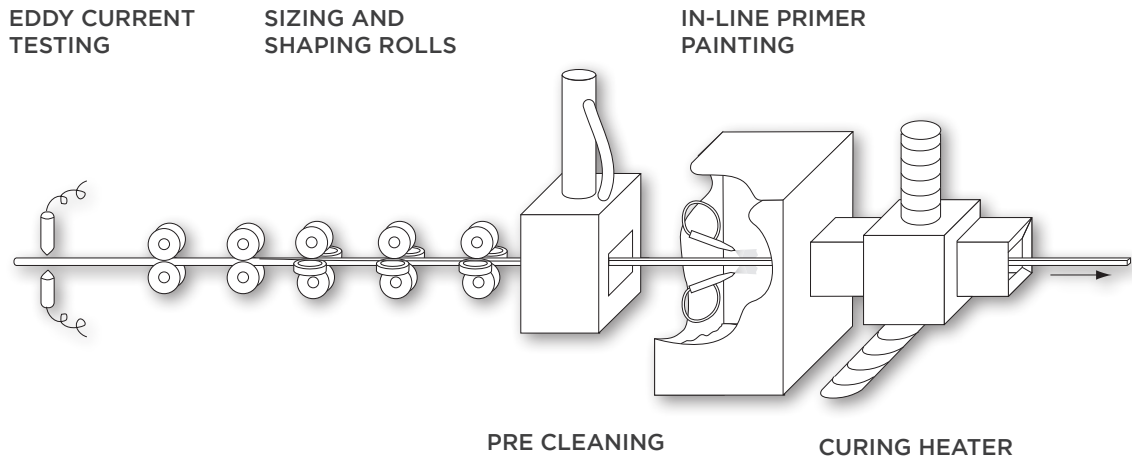

**Eddy Current Testing**

Weld quality is absolutely vital to the quality of the end products, its integrity is checked continuously (by our eddy current testing system) and any tube that does not conform is marked and rejected.

**Sizing and Shaping**

The tube then enters the sizing and shaping mill where rolls turn it into products such as square and rectangular hollow sections or other Austube Mills’ products. Quality inspections take place throughout the process to make sure the product conforms with specifications.

**Protective Painting**

These sections are then cleaned before entering the in-line coating process.

**ERW Process – Step 4**

**ELECTRONICALLY CONTROLLED CUT-OFF SAW**

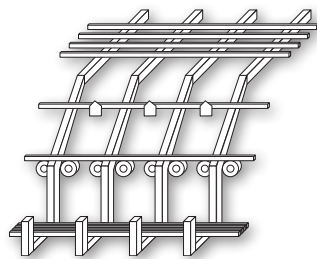
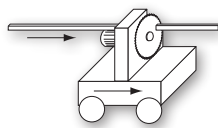

**RUN OUT CONVEYORS**

**COMPUTERISED BUNDLING**

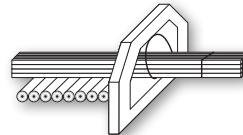

**MAGNETIC WAREHOUSE CRANE**

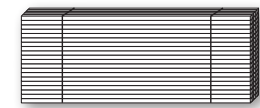
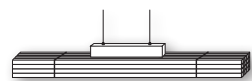

**UNDERCOVER WAREHOUSE STORAGE**

**Cut-off and Bundling**

After paint finishing, the product passes through an electronically controlled cut-off machine. Cut to specified lengths, the products then change direction and go through a run-out process en route to the bundler.

After a rigorous visual and dimensional inspection, most lengths of product go to the next step, those that have been ear-marked for rejection pass to one side. Tube products are then end faced to remove any jagged edges left by the cut off machine.

The bundler is a very complex process that sorts the product into pre-specified packs, wraps them with steel strap for transport and then removes them to the warehouse area.

The ends of the products are colour coded to identify wall thickness. Barcoded identification tags are also attached at this point.

**Despatch**

After weighing, they are put in the warehouse or are taken away for other operations, such as galvanizing.

Packs are lifted onto semi-trailer transporters, rail bases, or into shipping containers, for despatch to our distribution network throughout Australia, New Zealand, the Pacific Rim and South-East Asia.

## END OF LIFE (MODULES C1-C4)

When a building reaches its end-of-life, metal products are mostly recovered (due to their economic value) for recycling, although some material is lost or disposed of in a landfill.

Module C includes waste processing followed by recycling/landfill of the product. The scenarios included are currently in use and are representative for one of the most probable alternatives.

**Table 5: End of life scenarios for products**

Process	Unit (expressed per 1 t)		
Scenario	Main	100% recycling	100% landfill
<b>Collection process specified by type</b>	1 t of steel collected with mixed construction waste		
<b>Recovery system specified by type</b>	0.898 t for recycling* (DCCEEW, 2024)	1 t for recycling	0 t for recycling
<b>Disposal specified by type</b>	0.102 t modelled as inert material in landfill	0 t modelled as inert material in landfill	1 t modelled as inert material in landfill
<b>Assumptions for scenario development</b>	C1: <ul style="list-style-type: none"> <li>Demonition/deconstruction of steel - diesel use of 1.1 kWh/tonne</li> </ul> C2: <ul style="list-style-type: none"> <li>Transport to waste processing - 16-32 tonne lorry (EURO 5), 50% load factor for 80km</li> </ul> C3: <ul style="list-style-type: none"> <li>Loading and unloading at sorting facility - diesel use of 1.8 kWh/tonne</li> <li>Mechanical sorting - electricity use of 2.2 kWh/tonne</li> <li>Fragging of steel - diesel use of 7.4 kWh/tonne</li> </ul> C4: <ul style="list-style-type: none"> <li>Compacting of inert construction waste for landfills (including backfilling) - diesel use of 1.6 kWh/tonne</li> </ul>		

\*The European Union Guidance on PEF does not identify an R2 value for this EPD product. We have used the Australian resource recovery rate of metals (89.8%) in 2022-2023, based on (DCCEEW, 2024).

## RECOVERY AND RECYCLING POTENTIAL (MODULE D)

Scrap generated from the end-of-life (C1-C4) of this product system is first used to satisfy all input scrap demand for A1-A3, with net scrap assigned a credit or burden from module D. The end-of-life scrap is assigned as material for recycling and the incoming scrap is assigned as secondary material (module C3).

Module D starts at the end-of-waste state of net flows of secondary materials that leave the product life cycle from module C3. For the steel tubes covered in this study, the end-of-waste state is reached when scrap has been collected and sorted/pre-processed and is available to be purchased by a recycling facility. Module D therefore includes the transport from the scrap processor to the recycling plant, the recycling operation itself (via Electric Arc Furnace), and the avoided production of primary metal (via Basic Oxygen Steelmaking).

The net scrap for the EPD is calculated as the total amount available in module C3 minus the recycled content needed for modules A1-A3:

- DuraGal® Clear: (898 kg - 108 kg) = 790 kg/t

Module D starts with the transport of processed scrap from scrap dealers, municipal facilities, or other steelworks and includes the full recycling process (re-smelting in an electric arc furnace)

to produce new steel. The average transport between scrap processors and steel recycling facilities in Australia and overseas consists of 97 km by truck, plus 216 km by rail, plus 3 710 km by sea.

Once received at the EAF, dry paint and coating is assumed to burn off within the furnace. Steel (i.e., the base metal only) is then awarded a recycling credit/burden based on the “steel value of scrap”. The “steel value of scrap” is calculated as the difference between 100% primary steel production and 100% secondary steel production. For the sake of simplicity, it's assumed that the recycling process is done via electric arc furnace (EAF), given that the EAF accepts up to 100% scrap metal input. A burden is assigned to the EAF in module D. The avoided production of primary steel is assumed to be done with Basic Oxygen Furnace (BOF), to which credits are assigned in module D. We usedecoinvent datasets for BOF (steel production, converter, low-alloyed) and EAF (steel production, electric, low-alloyed).

## LCA SOFTWARE AND DATABASE

The LCA was conducted in Microsoft Excel. The model uses ecoinvent v3.11 (cut-off, EN15804 model) and Australian National Life Cycle Inventory Database (AusLCI) for electricity. Background datasets include capital goods and infrastructure as provided in the databases.

## ELECTRICITY

The composition of the residual electricity grid of New South Wales mix is modelled based on published data of the generation per fuel type, and the national electricity mix trade between states for the financial year 1st July 2022 – 30th June 2023 (Australian Government, 2024). The New South Wales residual electricity mix is made up of black coal (65.6%), solar (11.1%), wind (5.03%), hydro (4.74%), natural gas (2.01%), biomass (0.633%), biogas (0.379%), oil products (0.114%), and coal seam methane (0.00228%). The remaining electricity is imported: 5.29% is imported from Victoria, and 5.16% is imported from Queensland.

Onsite consumption (4.15%) is calculated based on the same source as the grid mix (Australian Government, 2024). The low voltage (<1kV) grid's transmission and distribution losses (5.33%) are calculated based on data from the Australian Energy Market Operator (AEMO, 2022).

The emission factor for the New South Wales mix residual grid mix for the GWP-GHG indicator is 0.855 kg CO<sub>2</sub>-eq./kWh (based on EF3.1).

The composition of the residual electricity grid mix of Queensland is modelled based on published data of the generation per fuel type, and the national electricity mix trade between states for the financial year 1st July 2022 – 30th June 2023 (Australian Government, 2024). The Queensland residual electricity mix is made up of black coal (69.2%), solar (12.9%), natural gas (9.54%), wind (3.22%), hydro (1.90%), coal seam methane (0.898%), biomass (0.742%), biogas (0.296%), and oil products (0.0274%). The remaining 1.24% is imported from New South Wales.

Onsite consumption (7.05%) is calculated based on the same source as the grid mix (Australian Government, 2024). The low voltage (<1k V) grid's transmission and distribution losses (6.44%) are calculated based on data from the Australian Energy Market Operator (AEMO, 2022).

The emission factor for the Queensland residual grid mix for the GWP-GHG indicator is 0.929 kg CO<sub>2</sub>-eq./kWh (based on EF3.1).

For Dalian, all electricity is collected into the grid and then distributed to the user, and there is no trade of electricity. Residual supply mix is therefore not applicable in China as it is identical to the consumption mix.

There is no generation-specific trade of electricity in the Chinese Northeast grid, and therefore, the residual grid mix is identical to the location-based grid mix. Electricity used at Dalian is modelled using the ecoinvent dataset for China Northeast Grid and is made up of hard coal (77.5%), wind (15.5%), nuclear (4.4%), hydro (1.9%), blast furnace gas (0.7%), oil (0.4%), and natural gas (0.3%). (Note that grid composition does not add to 100% due to rounding.)

The emission factor for China, Northeast Grid for the GWP-GHG indicator is 1.23 kg CO<sub>2</sub>-eq./kWh (based on EF3.1).

## ALLOCATION

Allocation generally follows the requirements of PCR 2019:14 v2.0.1 section 4.5 (EPD International, 2025b). Irrespective of any allocation between product systems, the inherent properties of the product and the packaging, such as calorific content or biogenic or fossil carbon content, are not allocated away and always follow the physical downstream flow and the product system that finally uses it.

### Allocation of co-products

Co-product allocation was applied for the manufacturing process:

Economic allocation:

- Based on the total annual value of the steel tubes versus the total annual value of the steel scrap sold and the total output quantity. The difference in revenue per mass from the product and co-products is greater than 25%.
- Steel tubes are the main product produced and sold by Austube. Therefore, 98.37% of the site-level LCI is allocated to the steel tubes. This is a weighted average across sites.
- Steel scrap is produced and has economic value. Scrap is sold for recycling outside of the product system. Therefore, 1.63% of the site-level LCI is allocated to the steel scrap. This is a weighted average across sites.

Mass allocation:

- Site-level data (e.g. electricity, natural gas, fuels and consumables) are attributed to various steel tubes, based on the mass of the products.
- Packaging used in final products is allocated based on the total throughput of packaged products.

### Allocation of waste

For cardboard waste materials (module A3), the end-of-waste state is reached after transport to a recycling facility. Cut-off allocation is applied at the system boundary. Any subsequent processing of the material is allocated to the subsequent product system and is not considered in this study.

General waste materials and paint/solvent waste do not fulfil end-of-waste criteria (module A3). Transport of the waste to a disposal (landfill) facility and the disposal (landfill) of the material is included.

## Recycling allocation

Steel waste materials from the production of tubes are sold to a steel scrap collector to be recycled. As such, the scrap from this product system is treated as a co-product and is economically allocated as described in Allocation of co-products.

Austube uses steel coils as an input. Coils are purchased from multiple suppliers: BlueScope Steel in Australia and Chinese steel coil producers in China. BlueScope Steel has EPDs ((BlueScope, 2024a), (BlueScope, 2024b), (BlueScope, 2020)) that declare 17.4% recycled content (including pre- and post-consumer materials). Steel from the Chinese supplier is modelled using secondary data from the steel production, converter, low-alloyed dataset in ecoinvent v3.11 that declares 15.6% secondary material.

The scrap in BlueScope EPDs and ecoinvent's steel dataset was not modelled in line with the requirements of the current PCR. As such, further scrap modelling for the input side has been undertaken. We assumed that 10% is pre-consumer scrap and 90% is post-consumer scrap in the upstream data. The burdens for pre-consumer scrap were modelled using the scrap sold from Austube as proxy. GWP-GHG impact of pre-consumer scrap is 0.868 kg CO<sub>2</sub>-eq./kg.

## Allocation of secondary data

Allocation of background data (energy and materials) taken from the ecoinvent database is documented online at <https://ecoquery.ecoinvent.org/>.

Specifically, steel produced via blast furnace technology generates co-products like blast furnace slag and gases. ecoinvent uses cut-off allocation for these co-products, assuming they have no economic value. This means all steel production is attributed to the main product (steel), with co-products considered waste and their end of waste defined at the steel plant. This allocation method remains unchanged and is conservative, as co-products are not utilised within the Austube system. Additionally, the primary and secondary economic data for these co-products are not updated or geographically specific at the time of the EPD release.

## DATA QUALITY ASSESSMENT

A data quality assessment was undertaken in compliance with EN 15941 (CEN, 2024), using the data quality level system and criteria set out in the UN Environment Global Guidance on LCA database development.

Data quality checks included mass balance, internal and external benchmarking and consistency checks across datasets.

**Table 5: Data sources and share of primary data**

Process category	Source type	Source	Reference year	Data category	Share of primary data, of GWP-GHG results for A1-A3
<b>Steel coils</b>	EPD & database	EPD Australasia & ecoinvent v3.11	2020-2024	Primary data, Rep. secondary data	0.4%
<b>Other raw materials</b>	Database	ecoinvent v3.11	2024	Rep. secondary data	0%
<b>Transport</b>	Database	ecoinvent v3.11	2024	Primary data, Rep. secondary data	5.1%
<b>Electricity used by Austube Mills</b>	Database	AusLCI	2024	Primary data	3.2%
<b>Other Energy used by Austube Mills</b>	Database	ecoinvent v3.11	2024	Primary data	0%
<b>Other (auxiliary, waste, maintenance)</b>	Database	ecoinvent v3.11	2024	Rep. secondary data	0%
<b>Total share of primary data, of GWP-GHG results for A1-A3</b>					<b>8.7%</b>

The reported share of primary data is associated with uncertainty, as an EPD used as data source lacks information on the share of primary data. It is a simplified indicator for data quality that supports the use of more primary data, to increase the representativeness of and comparability between EPDs. Note that the indicator does not capture all relevant aspects of data quality and is not comparable across product categories.

Use of data with fair representativeness and over 30% contribution to core indicators:

- Gal coil (China) and Steel coil (China): Datasets for steel production in China were not available in ecoinvent, and they were modelled using other available datasets instead.
  - In DuraGal® Clear, fair representation accounts for 91% of GWP-total, and 77%-99% of other core impact indicators.

Use of data with poor or very poor representativeness:

- No data with poor or very poor representativeness was used.

## MODELLING OF INFRASTRUCTURE/CAPITAL GOODS

Infrastructure and capital goods in production and end-of-life processes were not included in data collected for the product system, and therefore not within the system boundary. This is not regarded as limiting the scope of the inventory or as an incomplete inventory (i.e. a cut-off). However, background datasets provided by ecoinvent include capital goods and infrastructure. It is not possible, within reasonable effort, to subtract the data on infrastructure/capital goods from these datasets. Electricity generation is also an exception, where the capital goods are very important for modelling changes towards more renewable generation. Capital goods related to electricity generation are included in all electricity datasets used in this study.

## CUT OFF CRITERIA

In this study capital goods and infrastructure have been included in the background datasets as provided by ecoinvent. It is not possible, within reasonable effort, to subtract the data on infrastructure/capital goods from these datasets.

The following flows have been cut-off in line with EN15804 and PCR 2019:14 rules:

- Production of packaging for other raw materials e.g. coatings, finishings, or maintenance materials. These materials contribute less than 0.01% of cumulative mass but are captured in the disposal of general waste from manufacturing.
- Materials used for protecting steel products when transporting to site e.g. timber or rubber dunnage, R-clips, and interleaving. These materials, contributing less than 0.01% of cumulative mass, are not used to deliver the finished product and often reused between suppliers and Austube.
- Paint combustion during the recycling process of steel scrap in an electric arc furnace. The paint material contributes less than 0.25% of the mass of material undergoing recycling in module D.

## KEY ASSUMPTIONS

The following assumptions have been made in the LCA:

- Steel coils from Australia were modelled using their published EPDs representative to the products. These EPDs were converted from a declared unit of m<sup>2</sup> to kg, assuming the same coil thickness across all products. The sensitivity analysis showed that the most conservative option was selected.
- Steel coils from China were modelled by adapting ecoinvent datasets for steel production in other countries. The dataset was regionalised with replacing of core inputs (electricity, pig iron, and coke) to geographically relevant datasets.

## ASSESSMENT INDICATORS

The results tables describe the different environmental indicators for each product per declared unit, for each declared module. The EN 15804 reference package based on EF 3.1, February 2023 is used.

- Table 7 contains the core environmental impact indicators in accordance with EN 15804:2012+A2:2019, describing the potential environmental impacts of the product.
- Table 8 provides additional environmental impact indicators in accordance with EN 15804:2012+A2:2019.
- Table 9 shows the life cycle inventory indicators for resource use.
- Table 10 displays the life cycle inventory indicators for waste and other outputs.
- Table 11 displays biogenic carbon content indicators.

The estimated impact results are only relative statements, which do not indicate the endpoints of the impact categories, exceeding threshold values, safety margins and/or risks.

**Table 7: EN15804+A2 Core Environmental Impact Indicators**

Impact category	Indicator	Unit
Climate change - total	GWP-total	kg CO <sub>2</sub> -eq.
Climate change - fossil	GWP-fossil	kg CO <sub>2</sub> -eq.
Climate change - biogenic	GWP-biogenic	kg CO <sub>2</sub> -eq.
Climate change - land use and land use change	GWP-luluc	kg CO <sub>2</sub> -eq.
Ozone depletion	ODP	kg CFC11-eq.
Acidification	AP	Mole of H <sup>+</sup> eq.
Eutrophication aquatic freshwater	EP-freshwater	kg P eq.
Eutrophication aquatic marine	EP-marine	kg N eq.
Eutrophication terrestrial	EP-terrestrial	Mole of N eq.
Photochemical ozone formation	POCP	kg NMVOC eq.
Depletion of abiotic resources - minerals and metals <sup>1 2</sup>	ADP-m&m	kg Sb-eq.
Depletion of abiotic resources - fossil fuels <sup>1</sup>	ADP-fossil	MJ
Water use <sup>1</sup>	WDP	m <sup>3</sup> world equiv.

**Table 8: EN15804+A2 Additional Environmental Impact Indicators**

Impact Category	Indicator	Unit
Climate Change <sup>3</sup>	GWP-GHG	kg CO <sub>2</sub> -eq
Climate Change <sup>4</sup>	GWP-GHG (IPCC AR5)	kg CO <sub>2</sub> -eq
Particulate Matter emissions	PM	Disease incidences
Ionising Radiation - human health <sup>5</sup>	IRP	kBq U235 eq.
Eco-toxicity (freshwater) <sup>1,2</sup>	ETP-fw	CTUe
Human Toxicity, cancer <sup>1,2</sup>	HTP-c	CTUh
Human Toxicity, non-cancer <sup>1,2</sup>	HTP-nc	CTUh
Land use related impacts / soil quality <sup>1</sup>	SQP	Dimensionless (Pt)

**Table 9: Life cycle inventory indicators on use of resources**

Parameter	Indicator	Unit
Use of renewable primary energy excluding renewable primary energy resources used as raw materials	PERE	MJ
Use of renewable primary energy resources used as raw materials	PERM	MJ
Total use of renewable primary energy resources	PERT	MJ
Use of non-renewable primary energy excluding non-renewable primary energy resources used as raw materials	PENRE	MJ
Use of non-renewable primary energy resources used as raw materials	PENRM	MJ
Total use of non-renewable primary energy resources	PENRT	MJ
Use of secondary material	SM	kg
Use of renewable secondary fuels	RSF	MJ
Use of non-renewable secondary fuels	NRSF	MJ
Net use of fresh water	FW	M <sup>3</sup>

**Table 10: Lifecycle inventory indicators on waste categories and output flows**

Parameter	Indicator	Unit
Hazardous waste disposed	HWD	kg
Non-hazardous waste disposed	NHWD	kg
Radioactive waste disposed	RWD	kg
Components for reuse	CRU	kg
Materials for energy recovery	MER	kg
Materials for recycling	MFR	kg
Exported electrical energy	EEE	MJ
Exported thermal energy	EET	MJ

**Table 11: Biogenic carbon content indicators**

Parameter	Indicator	Unit
Biogenic carbon content - product	BCC-prod	kg C
Biogenic carbon content - packaging	BCC-pack	kg C

Note: 1 kg biogenic carbon is equivalent to 44/12 kg CO<sub>2</sub>

### Disclaimers

<sup>1</sup>The results of this environmental impact indicator shall be used with care as the uncertainties on these results are high or as there is limited experience with the indicator.

<sup>2</sup>The results of the impact categories abiotic depletion of minerals and metals, land use, human toxicity (cancer), human toxicity, noncancer and ecotoxicity (freshwater) may be highly uncertain in LCAs that include capital goods/infrastructure in generic datasets, in case infrastructure/capital goods contribute greatly to the total results. This is because the LCI data of infrastructure/capital goods used to quantify these indicators in currently available generic datasets sometimes lack temporal, technological and geographical representativeness. Caution should be exercised when using the results of these indicators for decision-making purposes.

<sup>3</sup>This indicator should be identical to GWP-total except that the CF for biogenic CO<sub>2</sub> is set to zero. It has been included in the EPD following the PCR (EPD International, 2023). In this study it is calculated by subtracting the value of Climate change – biogenic (GWP-biogenic) from the value of Climate change – total (GWP-total) since theecoinvent Excel LCIA results do not include the indicator.

<sup>4</sup>GWP-GHG (IPCC AR5) is an additional GWPI00 indicator that is aligned with the Intergovernmental Panel on Climate Change (IPCC) 2013 Fifth Assessment Report (AR5) (IPCC 2013), national greenhouse gas reporting frameworks in Australia and New Zealand and previous versions of the Construction Products PCR. It excludes biogenic carbon and indirect radiative forcing.

<sup>5</sup>This impact category deals mainly with the eventual impact of low dose ionizing radiation on human health of the nuclear fuel cycle. It does not consider effects due to possible nuclear accidents, occupational exposure nor due to radioactive waste disposal in underground facilities. Potential ionizing radiation from the soil, from radon and some construction materials, is also not measured by this indicator.

# Environmental Performance

The following tables show the results for one tonne of product.

The estimated impact results are only relative statements, which do not indicate the endpoints of the impact categories, exceeding threshold values, safety margins and/or risks.

The results of the end-of-life stage (modules C1-C4) should be considered when using the results of the product stage (modules A1-A3).

Biogenic carbon and/or recovered energy leaving the product system in module A5 has been balanced out already in modules A1-A3.

The use of primary energy is separated into energy used as raw material and energy used as energy carrier as per option B in Annex 3 in the PCR (EPD International, 2025).

Energy indicators (MJ) are always given as net calorific value.

## RESULTS OF PRIMARY SCENARIO

**Table 12: Core environmental indicator results for 1 t of DuraGal® Clear**

INDICATOR	UNIT	A1-A3	C1	C2	C3	C4	D	A-C Variation
<b>GWP-total</b>	kg CO <sub>2</sub> eq.	2.52E+03	3.99E-01	1.62E+01	4.68E+00	7.69E-02	-6.26E+02	16%
<b>GWP-fossil</b>	kg CO <sub>2</sub> eq.	2.52E+03	3.99E-01	1.62E+01	4.65E+00	5.91E-02	-6.31E+02	16%
<b>GWP-biogenic</b>	kg CO <sub>2</sub> eq.	3.17E+00	7.59E-05	4.60E-03	1.37E-02	1.77E-02	5.01E+00	<10%
<b>GWP-luluc</b>	kg CO <sub>2</sub> eq.	1.86E+00	4.08E-05	7.26E-03	1.32E-02	6.05E-06	4.25E-02	46%
<b>ODP</b>	kg CFC 11 eq.	1.44E-05	5.92E-09	2.05E-07	4.62E-08	8.78E-10	-7.25E-07	89%
<b>AP</b>	mol H <sup>+</sup> eq.	2.90E+01	3.56E-03	5.52E-02	4.05E-02	5.28E-04	-1.78E+00	55%
<b>EP-freshwater</b>	kg P eq.	1.60E+00	1.28E-05	1.77E-03	2.31E-04	1.90E-06	-5.84E-01	94%
<b>EP-marine</b>	kg N eq.	3.80E+00	1.66E-03	1.75E-02	1.44E-02	2.46E-04	-1.24E-01	32%
<b>EP-terrestrial</b>	mol N eq.	9.52E+01	1.82E-02	1.90E-01	1.58E-01	2.69E-03	-3.89E+00	65%
<b>POCP</b>	kg NMVOC eq.	1.13E+01	5.43E-03	7.48E-02	4.65E-02	8.06E-04	-1.19E+00	25%
<b>ADP-minerals&amp;metals <sup>12</sup></b>	kg Sb eq.	5.70E-02	1.43E-07	5.43E-05	2.34E-05	2.13E-08	-1.26E-02	<10%
<b>ADP-fossil <sup>1</sup></b>	MJ	3.15E+04	5.19E+00	2.24E+02	3.96E+01	7.70E-01	-5.44E+03	<10%
<b>WDP <sup>1</sup></b>	m <sup>3</sup> world eq. deprived	9.44E+02	1.34E-02	1.19E+00	6.96E-01	1.98E-03	4.25E+01	76%

Table 13: Additional environmental impact indicator results for 1 t of DuraGal® Clear

INDICATOR	UNIT	A1-A3	C1	C2	C3	C4	D	A-C Variation
<b>GWP-GHG</b> <sup>3</sup>	kg CO <sub>2</sub> eq.	2.52E+03	3.99E-01	1.62E+01	4.67E+00	5.91E-02	-6.31E+02	13%
<b>GWP-GHG (IPCC AR5)</b> <sup>4</sup>	kg CO <sub>2</sub> eq.	2.61E+03	4.09E-01	1.66E+01	4.80E+00	6.07E-02	-6.61E+02	11%
<b>PM</b>	Disease incidences	4.46E-04	1.02E-07	1.25E-06	8.73E-07	1.51E-08	-5.43E-05	62%
<b>IRP</b> <sup>5</sup>	kBq U235 eq.	6.93E+01	2.21E-03	1.80E-01	2.02E-02	3.28E-04	5.81E+00	79%
<b>ETP-fw</b> <sup>12</sup>	CTUe	3.13E+04	2.81E-01	4.13E+01	2.70E+00	4.17E-02	-1.29E+03	80%
<b>HTP-c</b> <sup>12</sup>	CTUh	4.52E-06	4.06E-11	2.72E-09	5.23E-10	6.03E-12	3.51E-07	88%
<b>HTP-nc</b> <sup>12</sup>	CTUh	3.88E-05	6.38E-10	1.39E-07	2.62E-08	9.47E-11	5.59E-05	39%
<b>SGP</b> <sup>12</sup>	dimensionless	8.69E+03	3.43E-01	1.31E+02	9.60E+00	5.09E-02	-3.01E+03	74%

Table 14: Resource use indicator results for 1 t of DuraGal® Clear

INDICATOR	UNIT	A1-A3	C1	C2	C3	C4	D
<b>PERE</b>	MJ	1.50E+03	3.26E-02	3.11E+00	2.25E+00	4.83E-03	-1.08E+03
<b>PERM</b>	MJ	1.46E-01	0	0	-1.31E-01	0	0
<b>PERT</b>	MJ	1.50E+03	3.26E-02	3.11E+00	2.12E+00	4.83E-03	-1.08E+03
<b>PENRE</b>	MJ	3.15E+04	5.19E+00	2.24E+02	3.96E+01	7.70E-01	-5.44E+03
<b>PENRM</b>	MJ	1.49E+01	0	0	-1.34E+01	0	0
<b>PENRT</b>	MJ	3.15E+04	5.19E+00	2.24E+02	2.62E+01	7.70E-01	-5.44E+03
<b>SM</b>	kg	2.75E+02	0	0	2.59E-03	0	0
<b>RSF</b>	MJ	0	0	0	1.66E-05	0	0
<b>NRSF</b>	MJ	0	0	0	0	0	0
<b>FW</b>	m <sup>3</sup>	2.15E+01	3.32E-04	3.00E-02	3.26E-02	4.93E-05	-1.15E+01

Table 15: Waste material and output flow indicator results for 1 t of DuraGal® Clear

INDICATOR	UNIT	A1-A3	C1	C2	C3	C4	D
<b>HWD</b>	kg	1.55E+01	5.82E-03	5.12E-01	5.48E-02	8.63E-04	1.48E+00
<b>NHWD</b>	kg	1.49E+02	8.48E-02	9.86E+00	1.24E+00	1.02E+02	4.16E+01
<b>RWD</b>	kg	1.75E-02	5.42E-07	4.42E-05	4.95E-06	8.05E-08	1.08E-03
<b>CRU</b>	kg	0	0	0	0	0	0
<b>MFR</b>	kg	1.87E-01	0	0	8.98E+02	0	0
<b>MER</b>	kg	0	0	0	0	0	0
<b>EEE</b>	MJ	0	0	0	0	0	0
<b>EET</b>	MJ	0	0	0	0	0	0

Table 16: Biogenic carbon content indicator results for 1 t of DuraGal® Clear

INDICATOR	UNIT	A1-A3
<b>BCC-prod</b>	kg	0
<b>BCC-pack</b>	kg	0

## VARIATION IN RESULTS

The results show variation higher than 10% across the product group for modules A-C as shown in the results tables above for multiple indicators. This EPD does not claim compliance with ISO 21930:2017. The variation above 10% of modules A-C is due to the variation in steel datasets used: BlueScope Steel EPD for Australian steel andecoinvent data for Chinese steel.

The variation in GWP-GHG at the production stage (A1-A3) is shown below. Variation of products is calculated based on how differences in thickness or size of products included in the grouped EPD results affect the footprint per tonne. Variation of sites is calculated based on identical products manufactured at different sites. As per PCR 2019:14, variations (in %) between two numbers are calculated by dividing the absolute difference of the numbers by their average and then multiplying the result by 100.

**Table 17: GWP-GHG A1-A3 variation**

PRODUCT GROUP	GWP-GHG (kg CO <sub>2</sub> e/t)	VARIATION - PRODUCTS	VARIATION - SITES
DURAGAL® CLEAR	2 520	13%	13%

## RESULTS FOR ADDITIONAL SCENARIOS

This section provides results for alternate end-of-life scenarios.

**Table 18: Core environmental indicator results for 1 t of DuraGal® Clear**

INDICATOR	UNIT	100% Recycling			100% Landfill		
		C3	C4	D	C3	C4	D
<b>GWP-total</b>	kg CO <sub>2</sub> eq.	5.21E+00	0	-7.07E+02	0	5.98E-01	8.55E+01
<b>GWP-fossil</b>	kg CO <sub>2</sub> eq.	5.18E+00	0	-7.13E+02	0	5.80E-01	8.62E+01
<b>GWP-biogenic</b>	kg CO <sub>2</sub> eq.	1.53E-02	0	5.66E+00	0	1.78E-02	-6.85E-01
<b>GWP-luluc</b>	kg CO <sub>2</sub> eq.	1.47E-02	0	4.79E-02	0	5.93E-05	-5.80E-03
<b>ODP</b>	kg CFC11 eq.	5.14E-08	0	-8.18E-07	0	8.60E-09	9.90E-08
<b>AP</b>	mol H <sup>+</sup> eq.	4.51E-02	0	-2.01E+00	0	5.18E-03	2.43E-01
<b>EP-freshwater</b>	kg P eq.	2.58E-04	0	-6.59E-01	0	1.86E-05	7.97E-02
<b>EP-marine</b>	kg N eq.	1.60E-02	0	-1.40E-01	0	2.41E-03	1.70E-02
<b>EP-terrestrial</b>	mol N eq.	1.76E-01	0	-4.40E+00	0	2.64E-02	5.31E-01
<b>POCP</b>	kg NMVOC eq.	5.18E-02	0	-1.34E+00	0	7.90E-03	1.62E-01
<b>ADP-minerals&amp;metals<sup>12</sup></b>	kg Sb-eq.	2.61E-05	0	-1.42E-02	0	2.08E-07	1.72E-03
<b>ADP-fossil<sup>1</sup></b>	MJ	4.41E+01	0	-6.14E+03	0	7.55E+00	7.42E+02
<b>WDP<sup>1</sup></b>	m <sup>3</sup> world deprived	7.75E-01	0	4.80E+01	0	1.94E-02	-5.80E+00

Table 19: Additional environmental impact indicator results for 1 t of DuraGal® Clear

INDICATOR	UNIT	100% Recycling			100% Landfill		
		C3	C4	D	C3	C4	D
<b>GWP-GHG</b> <sup>3</sup>	kg CO <sub>2</sub> eq.	5.20E+00	0	-7.12E+02	0	5.80E-01	8.62E+01
<b>GWP-GHG (IPCC AR5)</b> <sup>4</sup>	kg CO <sub>2</sub> -eq.	5.34E+00	0	-7.46E+02	0	5.95E-01	9.03E+01
<b>PM</b>	Disease incidences	9.72E-07	0	-613E-05	0	1.48E-07	7.42E-06
<b>IRP</b> <sup>5</sup>	kBq U235 eq.	2.25E-02	0	6.56E+00	0	3.21E-03	-7.93E-01
<b>ETP-fw</b> <sup>12</sup>	CTUe	3.01E+00	0	-1.45E+03	0	4.09E-01	1.76E+02
<b>HTP-c</b> <sup>12</sup>	CTUh	5.82E-10	0	3.97E-07	0	5.91E-11	-4.80E-08
<b>HTP-nc</b> <sup>12</sup>	CTUh	2.92E-08	0	6.32E-05	0	9.29E-10	-7.64E-06
<b>SGP</b> <sup>12</sup>	dimensionless	1.07E+01	0	-3.4E3+03	0	4.99E-01	4.11E+02

Table 20: Resource use indicator results for 1 t of DuraGal® Clear

INDICATOR	UNIT	100% Recycling			100% Landfill		
		C3	C4	D	C3	C4	D
<b>PERE</b>	MJ	2.51E+00	0	-1.21E+03	0	4.74E-02	1.47E+02
<b>PERM</b>	MJ	-1.46E-01	0	0	0	0	0
<b>PERT</b>	MJ	2.36E+00	0	-1.21E+03	0	4.74E-02	1.47E+02
<b>PENRE</b>	MJ	4.41E+01	0	-6.14E+03	0	7.55E+00	7.43E+02
<b>PENRM</b>	MJ	-1.49E+01	0	0	0	0	0
<b>PENRT</b>	MJ	2.92E+01	0	-6.14E+03	0	7.55E+00	7.43E+02
<b>SM</b>	kg	2.88E-03	0	0	0	0	0
<b>RSF</b>	MJ	1.85E-05	0	0	0	0	0
<b>NRSF</b>	MJ	0	0	0	0	0	0
<b>FW</b>	m <sup>3</sup>	3.63E-02	0	-1.30E+01	0	4.83E-04	1.57E+00

Table 21: Waste material and output flow indicator results for 1 t of DuraGal® Clear

INDICATOR	UNIT	100% Recycling			100% Landfill		
		C3	C4	D	C3	C4	D
<b>HWD</b>	kg	6.11E-02	0	1.67E+00	0	8.46E-03	-2.02E-01
<b>NHWD</b>	kg	1.38E+00	0	4.70E+01	0	1.00E+03	-5.68E+00
<b>RWD</b>	kg	5.51E-06	0	1.21E-03	0	7.89E-07	-1.47E-04
<b>CRU</b>	kg	0	0	0	0	0	0
<b>MFR</b>	kg	1.00E+03	0	0	0	0	0
<b>MER</b>	kg	0	0	0	0	0	0
<b>EEE</b>	MJ	0	0	0	0	0	0
<b>EET</b>	MJ	0	0	0	0	0	0

# General information

An Environmental Product Declaration, or EPD, is a standardised and verified way of quantifying the environmental impacts of a product based on a consistent set of rules known as a PCR (Product Category Rules). Austube Mills has the sole ownership, liability, and responsibility for the EPD.

EPDs within the same product category but published in different EPD programmes may not be comparable. For two EPDs to be comparable, they shall be based on the same PCR (including the same first-digit version number) or be based on fully-aligned PCRs or versions of PCRs; cover products with identical functions, technical performances and use (e.g. identical declared/functional units); have identical scope in terms of included life-cycle stages (unless the excluded life-cycle stage is demonstrated to be insignificant); apply identical impact assessment methods (including the same version of characterisation factors); and be valid at the time of comparison. For further information about comparability, see EN 15804 and ISO 14025.

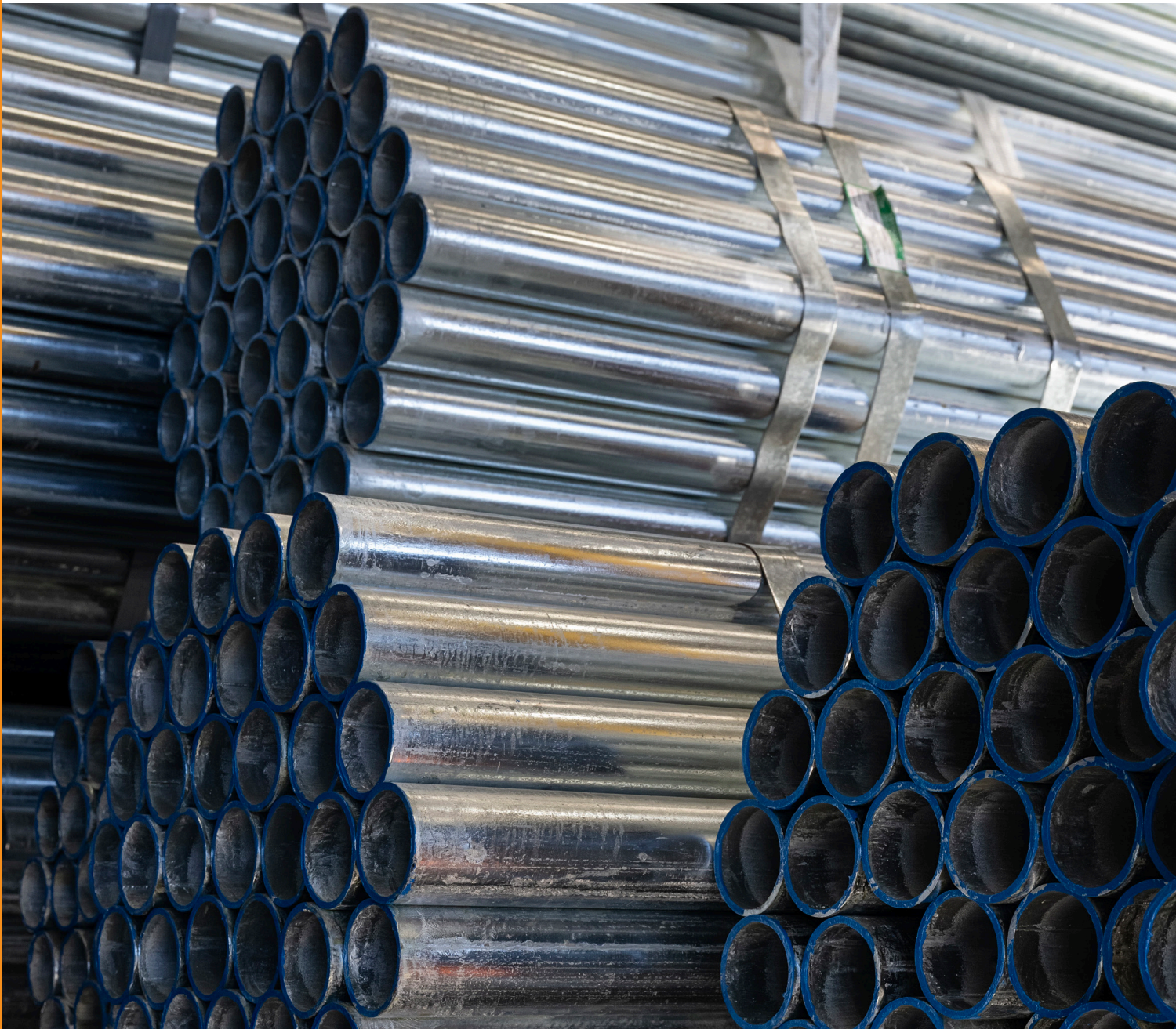

# Version History

001: Initial release

# Abbreviations

ADP	Abiotic Depletion Potential
AP	Acidification Potential, Accumulated Exceedance
CEN	European Committee for Standardization
CHS	Circular Hollow Section
DQA	Data Quality Assessment
EoL	End-of-Life
EP	Eutrophication Potential
ETP	Potential Comparative Toxic Unit for ecosystems
ff	fossil fuels
fw	fresh water
GHG	Greenhouse Gas
GWP	Global Warming Potential (Climate Change)
HTP	Potential Comparative Toxic Unit for humans
IRP	Potential Human exposure efficiency relative to U235
ISO	International Organization for Standardization
LCA	Life Cycle Assessment
LCI	Life Cycle Inventory
LCIA	Life Cycle Impact Assessment
luluc	Land use and land use change
m&m	minerals and metals
NDT	Non-Destructive Testing
NMVO	Non-Methane Volatile Organic Compound
NZ	New Zealand
ODP	Depletion potential of the stratospheric ozone layer
PM	Potential incidence of disease due to PM emissions
POCP	Formation potential of tropospheric ozone
RHS	Rectangular Hollow Section
SHS	Square Hollow Section
VOC	Volatile Organic Compound
WDP	Water (user) deprivation potential, deprivation-weighted water consumption

# References

AEMO. (2022). DISTRIBUTION LOSS FACTORS FOR THE 2021/22 FINANCIAL YEAR v8.0. Australian Energy Market Operator. Retrieved from [https://aemo.com.au/-/media/files/electricity/nem/security\\_and\\_reliability/loss\\_factors\\_and\\_regional\\_boundaries/2021-22/distribution-loss-factors-for-the-2021-22-financial-year.pdf?la=en](https://aemo.com.au/-/media/files/electricity/nem/security_and_reliability/loss_factors_and_regional_boundaries/2021-22/distribution-loss-factors-for-the-2021-22-financial-year.pdf?la=en)

Australian Government. (2024, June). Australian Energy Update 2023. Canberra: Australian Government Department of Climate Change, Energy, the Environment and Water. Retrieved from <https://www.energy.gov.au/publications/australian-energy-update-2023>

CEN. (2019/2021). EN 15804:2012+A2:2019/AC:2021, Sustainability of construction works – Environmental product declarations – Core rules for the product category of construction products. Brussels: European Committee for Standardization.

DCCEEW. (2024, December 12). Resource recovery and waste materials analysis. Retrieved from Department of Climate Change, Energy, the Environment and Water: <https://www.dcceew.gov.au/environment/protection/waste/publications/national-waste-resource-recovery-reporting/resource-recovery-waste-material-analysis-2024>

ECO Platform. (2024). ECO Platform standards, versions published 2024-12-20. Available on <https://www.ecoplatform.org/our-relevant-documents.html>. ECO Platform.

EPD Australasia. (2024). Instructions of the Australasian EPD Programme V4.2. Nelson: EPD Australasia Ltd.

EPD International. (2025a). General Programme Instructions for the International EPD System. Version 5.0.1 published 2025-02-27. Stockholm: EPD International.

EPD International. (2025b). PCR 2019:14 Construction Products version 2.0.1 of 2025-06-05 (valid until 2030-04-07). Stockholm: EPD International.

European Commission. (2022). Environmental Footprint reference package 3.1. Retrieved from European Platform on LCA (EPLCA): <https://eplca.jrc.ec.europa.eu/LCDN/developerEF.html>



ISO. (2006a). ISO 14040: Environmental management – Life cycle assessment – Principles and framework. Geneva: International Organization for Standardization.

ISO. (2006b). ISO 14044: Environmental management – Life cycle assessment – Requirements and guidelines. Geneva: International Organization for Standardization.

ISO. (2006c). ISO 14025: Environmental labels and declarations - Type III environmental declarations - Principles and procedures. Geneva: International Organization for Standardization.

thinkstep-anz. (2024). Australian Electricity Residual Supply Mixes FY2023 Factors. thinkstep-anz. Perth: thinkstep-anz. Retrieved from <https://www.thinkstep-anz.com/software/residual/>

Wernet, G. B.-R. (2016). The ecoinvent database version 3 (part I): overview and methodology. The International Journal of Life Cycle Assessment, 21(9) ([online]), 1218–1230.

PROGRAMME INFORMATION	
<b>EPD programme operator:</b>  INTERNATIONAL EPD SYSTEM	<b>EPD International AB</b> Web: <a href="http://www.environdec.com">www.environdec.com</a> Email: <a href="mailto:support@environdec.com">support@environdec.com</a> Post: EPD International AB, Box 210 60, SE-100 31 Stockholm, Sweden
<b>Licensee:</b>  INTERNATIONAL EPD SYSTEM	<b>EPD Australasia Limited</b> Web: <a href="http://www.epd-australasia.com">www.epd-australasia.com</a> Email: <a href="mailto:info@epd-australasia.com">info@epd-australasia.com</a> Post: EPD Australasia Limited, 6 Cube Court, Richmond 7020, New Zealand
PRODUCT CATEGORY RULES (PCR)	
<b>CEN standard EN 15804 served as the core Product Category Rules (PCR)</b>	
<b>PCR:</b>	PCR 2019.14 Construction Products, version 2.0.1 (published on 2025-06-05, valid until 2030-04-07)
<b>PCR review was conducted by:</b>	The Technical Committee of the International EPD System. See <a href="http://www.environdec.com">www.environdec.com</a> for a list of members.
<b>Review Chairs:</b>	Rob Rouwette (chair) start2see Noa Meron (co-chair) thinkstep-anz The review panel may be contacted via the Secretariat: <a href="http://www.environdec.com/contact">www.environdec.com/contact</a>
VERIFICATION	
<b>External and independent ('third-party') verification of the declaration and data, according to ISO 14025:2006, via EPD verification through:</b>	
<input checked="" type="checkbox"/> Individual EPD verification without a pre-verified LCA/EPD tool <input type="checkbox"/> Individual EPD verification with a pre-verified LCA/EPD tool <input type="checkbox"/> EPD Process Certification* without a pre-verified LCA/EPD tool <input type="checkbox"/> EPD Process Certification* with a pre-verified LCA/EPD tool <input type="checkbox"/> Fully pre-verified EPD tool	
<b>Third party verifier:</b> 	<b>Rob Rouwette - start2see</b> Web: <a href="http://www.start2see.com.au">www.start2see.com.au</a> Email: <a href="mailto:rob.rouwette@start2see.com.au">rob.rouwette@start2see.com.au</a>
<b>Verifier approved by:</b>	EPD Australasia Ltd and The International EPD System
<b>Procedure for follow-up of data during EPD validity involved third-party verifier</b>	<input type="checkbox"/> Yes <input checked="" type="checkbox"/> No
<b>Geographical scope:</b>	Australia
<b>Reference Year for Data:</b>	2023-07-01 to 2024-06-30



**AustubeMills**

*SHAPING POSSIBILITIES*